

**BWEA 30
Grid for
Busy People**

**The GBSQSS -
What Does it Do for Me
And Why Should I Care?**

Robert Longden
UK Regulatory Affairs Manager

Scottish and Southern Energy

- Scottish and Southern Energy is one of the largest energy companies in the UK. We are involved in the generation, transmission, distribution and supply of electricity; energy trading; the storage, distribution and supply of gas; electrical and utility contracting; and telecoms
- SSE's core purpose is to provide the energy people need in a reliable and sustainable way and we have set out an investment plan to 2013 of over **£3 billion** in renewables. By 2013 SSE intends to have doubled its renewable energy portfolio to 4,000MW, maintaining and extending its current lead as the largest renewable energy generator in the UK
- We have set a sector-leading target of reducing the carbon intensity of our entire power generating portfolio by 50% by 2020.

The Great Britain Security and Quality of Supply Standard (SQSS)

- Background
- Application of the current GB SQSS
- Perceived shortcomings
- Reviewing the GB SQSS
- How it fits in with other Initiatives

The GBSQSS - Where Does it Come From? (1)

- CEGB standards were adopted at time of privatisation
- Review of security standards following privatisation in 1990
 - OFFER requested review in 1992
 - Concluded that deterministic rule should be retained
 - Investment in additional transmission capacity if economically justified
 - Design variations** based on customer requests introduced
- Single Security and Quality of Supply (SQSS) standard introduced in 2000
 - Planning and operational sections in one document
 - Refined for BETTA in 2004 to give the current GB SQSS
 - Still includes the “circle diagram” based on measurement from the 1940s – more later

Where does it come from? (2)

Transmission Licence Obligation - C17 and D3

'The licensee shall at all times:

- (a) plan, develop and operate the licensee's transmission system;
and*
- (b) co-ordinate and direct the flow of electricity onto and over the
GB transmission system,*

*in accordance with the GB Security and Quality of Supply Standard
version 1,'*

*'The licensee shall at all times plan and develop the licensee's
transmission system in accordance with the GB SQSS,..... and shall,
in so doing, take into account the system operator's obligations under
standard condition C17 (Transmission system security standard and
quality of service) to coordinate and direct the flow of electricity onto
and over the GB transmission system.'*

What's In The Standard?

The GB SQSS – Contents

- 1 Introduction
- 2 Design of **Generation Connections**
- 3 Design of Demand Connections
- 4 Design of the **Main Interconnected Transmission System**
- 5 **Operation** of the *GB transmission system*
- 6 Voltage Limits in Planning and Operating the *GB transmission system*
- 7 Terms and Definitions

Appendices (including Appendix E Guidance on **Economic Justification**)

Document Structure

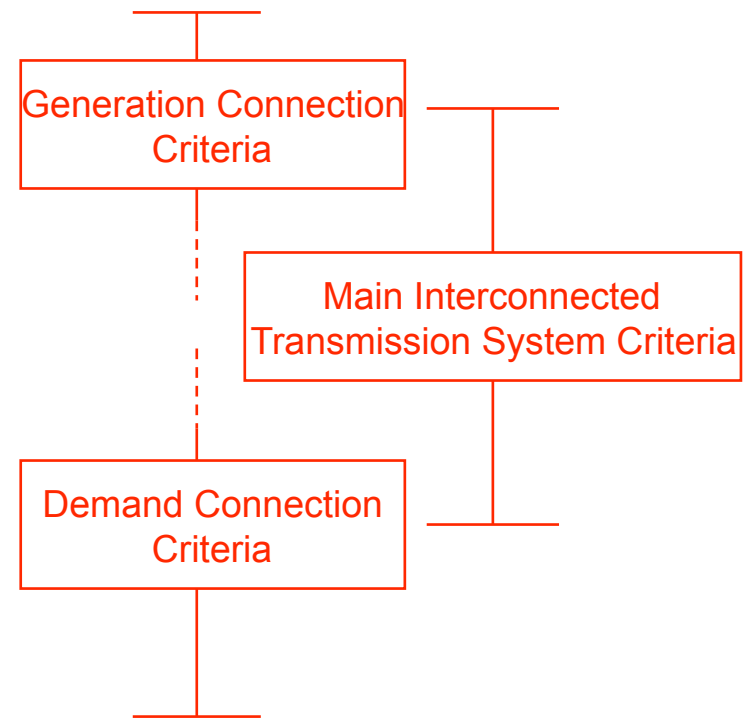
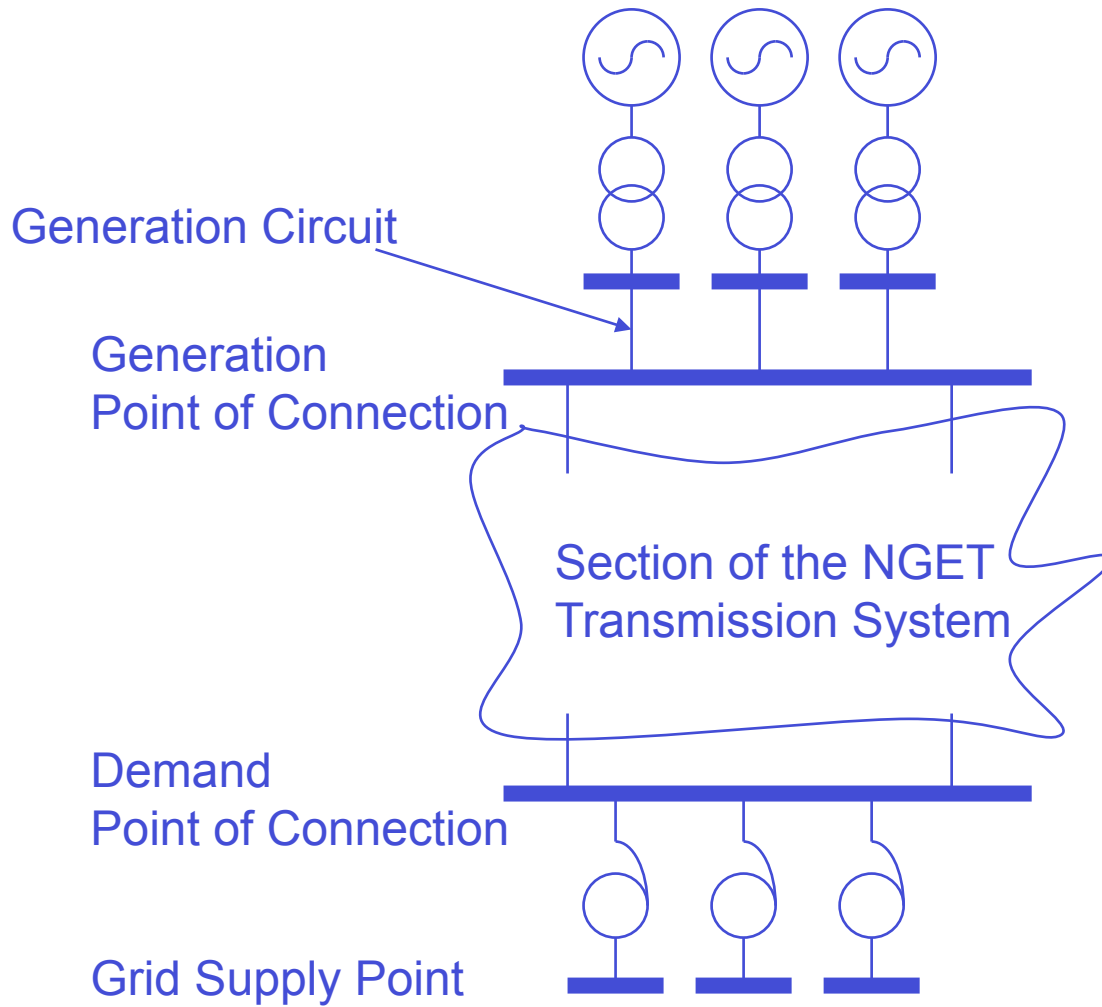

The Circle Diagram

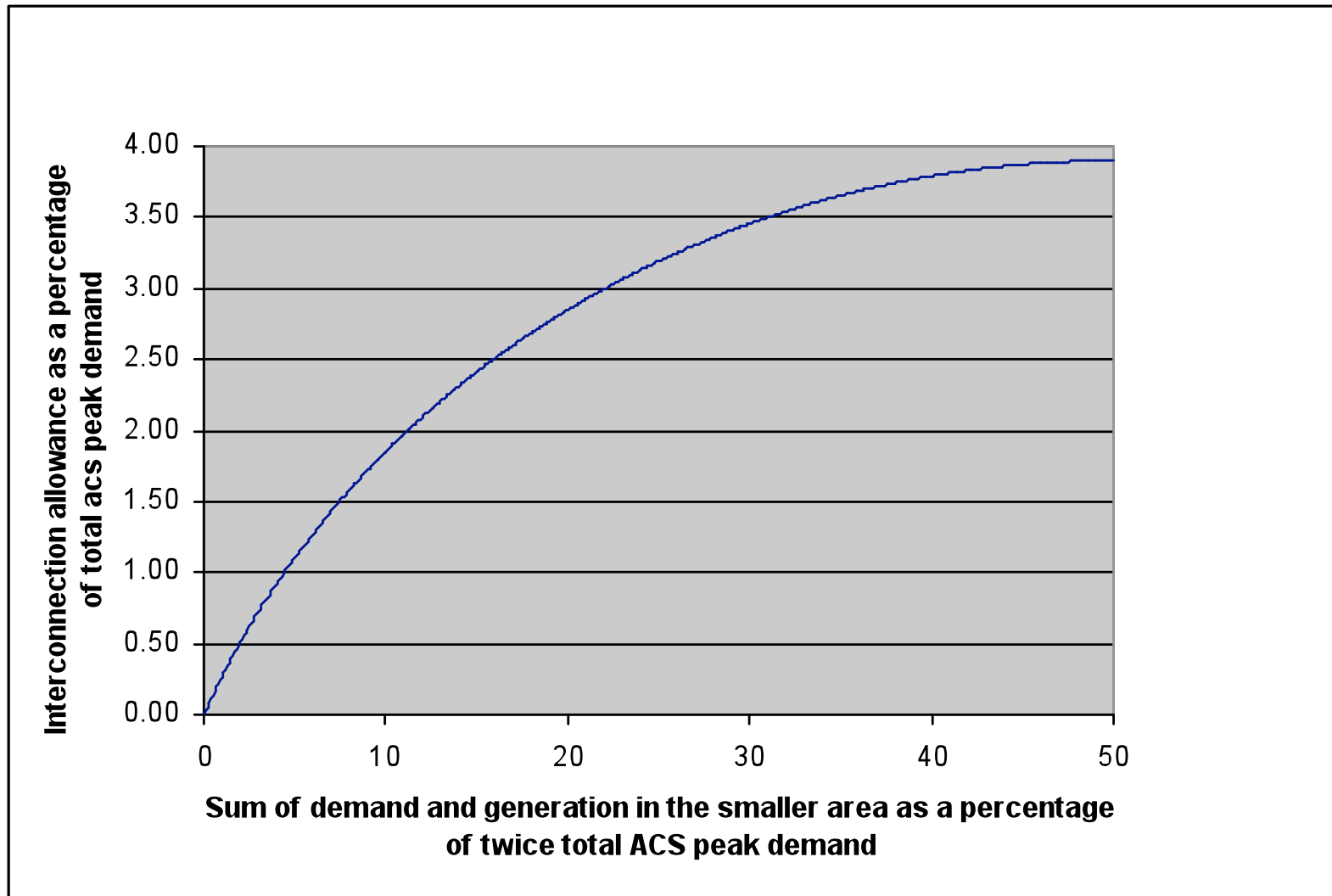

What Does the SQSS Do For Me?

- It dictates the design [and therefore **COST**] of Generation Connections – and provides the basis for design variations
- It provides the basis for design of the Main Interconnected Transmission System – influencing what users **pay** and the ability of the system to transport energy to **market**
- It specifies how the GB transmission system will be operated *and by implication – the effects on users*
- It specifies the Voltage Limits in Planning and Operating the GB transmission system and therefore contributes to the **capabilities** required from generators
- It sets out the basis for **Economic Justification** in analysing the operational/asset tradeoffs across the system

Transmission Capacity

- The SQSS aims to ensure that there is adequate transmission capacity to meet market requirements, by applying two criteria:
 - Ensuring sufficient transmission capacity is available as not to *unduly* restrict generation at time of peak
 - Ensuring sufficient transmission capacity is available to not *unduly* restrict market operations throughout the year for all reasonably foreseeable generation backgrounds
- This is achieved by:
 - Application of deterministic criteria (N-2) against all reasonably foreseeable generation backgrounds for all year round operation
 - Application of deterministic criteria (N-2) at time of winter peak
 - Supplemented by cost benefit analysis, which is undertaken against deterministic criteria (N-3) and assumes all operational actions are available

What do Capacity Decisions Mean In Practice?

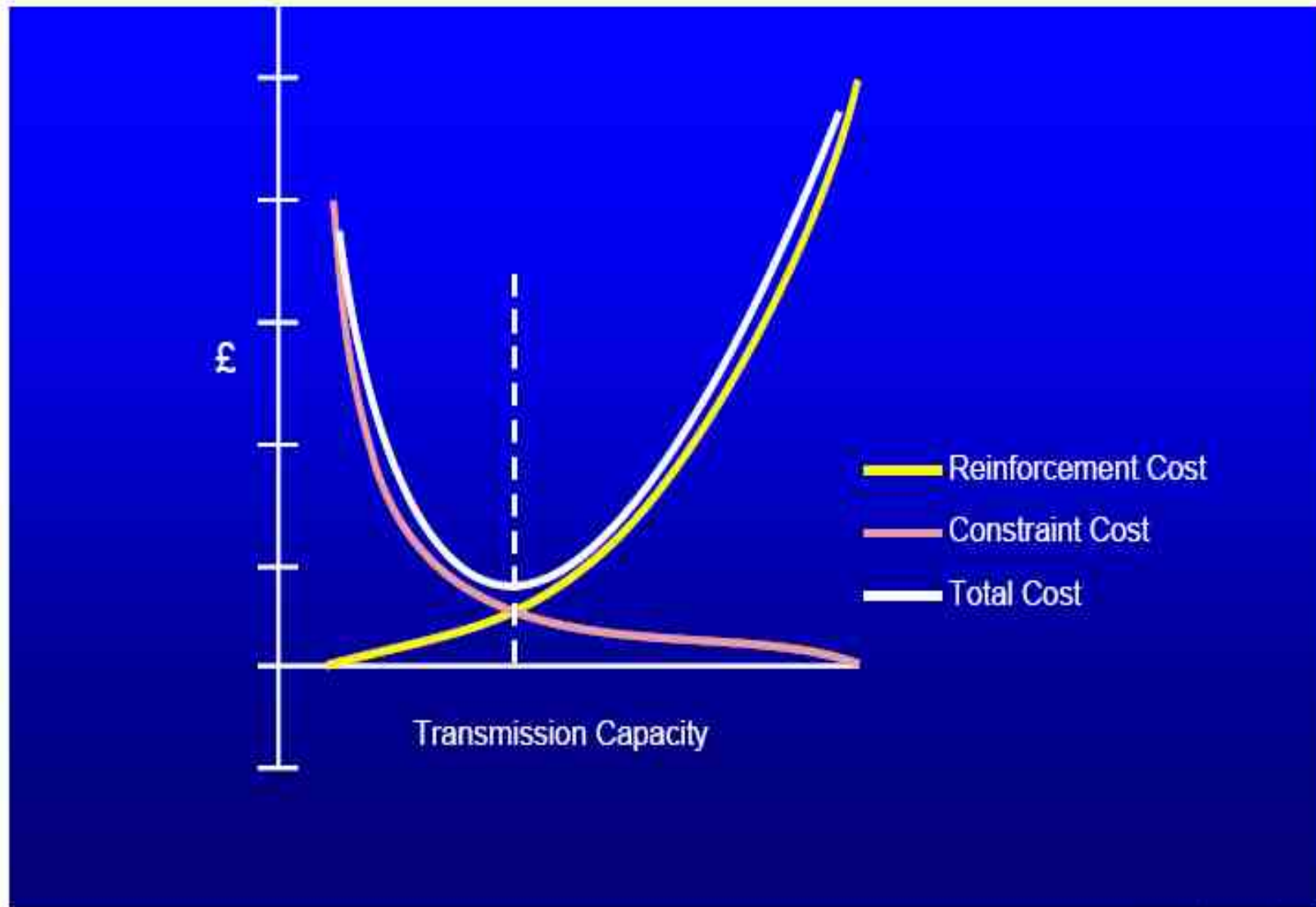

Operational Adequacy and Security

The transmission system is 'adequate' if it:

- is meeting all demand to requisite quality
- does not breach plant limits
- is stable

From a GB SQSS point of view, the system is 'secure' if it is presently adequate but also would be following defined 'secured events'

- single circuit fault outage, reactive compensator or reactive power provider
- double circuit outage (double circuit OHL and single with prior outage)
- loss of infeed – generator connections
- fault outage of section of busbar

Perceived shortcomings

- Current GB SQSS is based on a *conventional generation mix* of largely dispatchable, - or inflexible – plant – but with “known” output
- Considerable renewable generation [a high proportion of which will be variable] will be connecting to the GB system over the next decade
- Need to ensure the GBSQSS delivers its objectives against this new background, especially w.r.t.
 - Network asset investment for renewables
 - Maintaining appropriate Security of Supply standards
 - Operating the system

Perceived shortcomings (2)

- Treatment of wind in current SQSS studies
 - Wind generation significantly different from conventional generation
 - Current assumptions based on limited wind data
 - Suitability of deterministic criteria
- Does the existing SQSS provide an appropriate level of Security of Supply?
 - Plant margin
 - Treatment of contributory and non-contributory plant
 - Existing circle diagram and continued applicability
 - Wind penetration and ‘boundary size’
- Current methodology to deal with wind “not transparent”

Fundamental Review – by the “Review Group”

- GB SQSS pivotal in:
 - connection of generation & demand
 - efficient market operation
- The GB SQSS Review Group is carrying out a holistic, coordinated review of the GB SQSS to ensure it remains robust and able to support the integration of new generation technologies
- This is to ensure that there is a transparent basis for transmission investment in the GB electricity market and that this is coordinated with other changes to the commercial frameworks.
- This review builds upon the GB SQSS review work already in progress.

Fundamental Review – by the “Review Group”

- Two reviews of the GB SQSS are currently in consultation (Review for Onshore Intermittent Generation (GSR001) and Housekeeping (GSR002)) and the Review of Generation Connection (GSR003) is at an advanced stage.
- GSR001 conclusions will be incorporated in this review
- In the meantime, the Transmission Licensees will continue using the current methodology based on 60% scaling factor for wind generation in the GB SQSS
- The outcome from GSR002 will be incorporated at the GB SQSS redrafting stage. The GSR003 working group will continue its review work on generation connection.
- The Review Group has sought engagement from Stakeholders and is now under way

GB SQSS Review – Fit with Other Initiatives

Review will:

- incorporate cross-industry views
- be co-ordinated with Transmission Access Reform
- recognise the work of the [BERR/DECC] Energy Network Strategy Group
- Ensure that developing proposals for Strategic Network Investment [by the TOs] are incorporated in the analyses

Conclusions

- The GBSQSS is important to users – it influences both costs and operational practices
- After several issue specific reviews, there is now a Fundamental Review underway which has a direct bearing on renewable generation, now and in the future
- It will be carried out under a “joined up” process which links in with Transmission Access Reform and Strategic Network Investment
- Users need to engage with the process either directly, or via the BWEA